

Efficient control of rapid and creep speed in machine saws**● Application:**

Compact construction because all functions are integrated in the flange

● Flow regulator in the flange, external installation also possible on request

● Suitable for integrated electronic accumulator charging control with protection, pressure release and unloaded start-up

● Option:

Possible to extend the control using ML Valve Stacking System

Technical specifications

P_{max} = up to 250 bar

Q_{max} = up to 20 l/min

According to EN 60034-1 suitable for:

Short-term operation:

S2 = 5 min* (average value)

Intermittent operation:

S3 = 20 %* (average value)

* maximum oil temperature of 80 °C must not be exceeded

HYDAC Compact Power Unit CO1 MS21

for use in Machine Saws

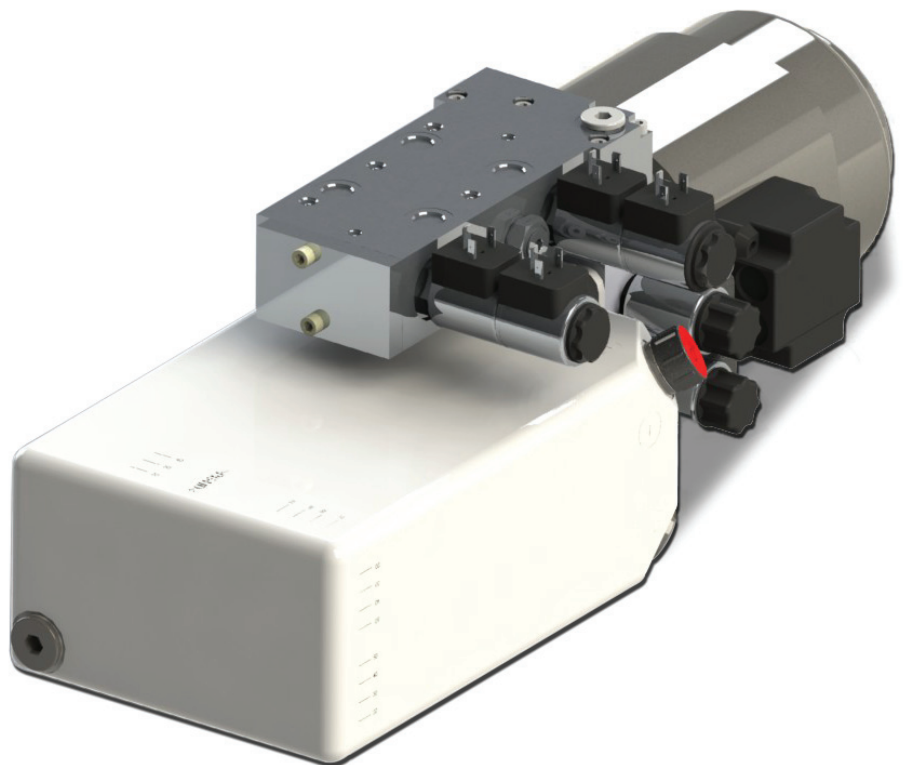

Mounting position of power unit

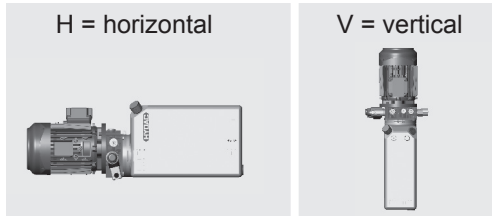

Motor / reservoir orientations



NOTE: Reservoir orientation T not possible if ML stacking valves are to be added

Model Code

Example: **CO1 H B04 R - 2.4 - 170 - 03 - MS21 - DB250V - WWW-S4.0-0 - B1/MA4 - 24DG+ ML+24DG+B1/ML 2xSC+EM**

Power unit	Flange control	Add-on parts	Valve voltage	Example: Valve stacking module
Power unit series Installation position Oil reservoir (see table 5.3) Motor / reservoir orientation Flow rate + max. possible pressure Motor voltage (see table page 3)	MS21 MS41	DB250V CE150 V W Z Y RV G 0 A3/A4/A5 S4.0 0 G 0	24DG 230AG Z4	ML+24DG+B1/ML 2xSC+EM
CO1 = Power unit series H = horizontal B04 = length 165 mm R = right 2.4 = flow rate 170 = max. possible pressure 03 = 3 phase 230/400 V - 50 Hz MS21 = pressure relief valve at position 2 DB250V = DB4E up to 250 bar (not pre-set) WWW = WSM 06020 W - 01 S4.0-0 = Flow regulator SRE1 with pre-set flow rate = 4.0 l/min B1/MA4 = pressure gauge Ø 63mm c/w adapter 400 bar 24DG+ = 24 V DC coil without connector ML+24DG+B1/ML 2xSC+EM = stacking module from the ML range	MS21 = pressure relief valve at position 2 MS41 = pressure relief valve at position 4	DB250V200 = DB4E pre-set to 200 bar DB250V = DB4E up to 250 bar (not pre-set) CE150 = DB4E...CE (CE approved) set to 150 bar V = WSM 06020 V - 01 W = WSM 06020 W - 01 Z = WSM 06020 Z - 01 Y = WSM 06020 Y - 01 RV = RVM 06020 - 01 G = closed blanking plug 0 = open blanking plug A3/A4/A5 = adapter named according to position S4.0 = Flow regulator SRE1 with pre-set flow rate = 4.0 l/min 0 = without flow regulator (open blanking plug) G = closed blanking plug 0 = open blanking plug	24DG = 24 V DC coil without connector 230AG = 230 V AC coil without connector Z4 = with connector Z4 (no details: no connector)	ML+24DG+B1/ML 2xSC+EM = stacking module from the ML range

Valves

- DB250V200** = DB4E pre-set to 200 bar
- DB250V** = DB4E up to 250 bar (not pre-set)
- CE150** = DB4E...CE (CE approved) set to 150 bar
- V** = WSM 06020 V - 01
- W** = WSM 06020 W - 01
- Z** = WSM 06020 Z - 01
- Y** = WSM 06020 Y - 01
- RV** = RVM 06020 - 01
- G** = closed blanking plug
- 0** = open blanking plug
- A3/A4/A5** = adapter named according to position
- S4.0** = Flow regulator SRE1 with pre-set flow rate = 4.0 l/min
- 0** = without flow regulator (open blanking plug)
- G** = closed blanking plug
- 0** = open blanking plug

Only possible at position 5

Add-on equipment

- DS1** = mech. pressure switch. 10-100 bar (connector not supplied)
- DS2** = mech. pressure switch 50-200 bar (connector not supplied)
- EDS3** = EDS 3446-2-250-000
- EDS8** = EDS 8446-2-250-000
- MA1** = pressure gauge Ø 63mm c/w adapter 160 bar
- MA2** = pressure gauge Ø 63mm c/w adapter 250 bar
- MA4** = pressure gauge Ø 63mm c/w adapter 400 bar
- M** = Minimes

Valve voltage

- 24DG** = 24 V DC coil without connector
- 230AG** = 230 V AC coil without connector
- Z4** = with connector Z4 (no details: no connector)

Build-on controls

- ML** = stacking module from the ML range (see brochure no. 5.308 ML)

* see circuit diagram on page 3

Oil reservoir

Reservoir code	Filling volume / Usable volume [l]**			Reservoir length [mm]
	Horizontal, reservoir position R and L	Horizontal, reservoir position T**	Vertical	
B04	1.9 / 1.5	2.2 / 2.0	1.8 / 1.2	165* ± 5
B05	2.7 / 2.2	3.0 / 2.7	3.0 / 2.4	220* ± 5
B08	4.4 / 3.5	5.1 / 4.6	5.1 / 4.5	340* ± 5
B12	6.5 / 5.2	8.4 / 7.6	8.4 / 7.8	500* ± 5

* where mounted horizontally, support for oil reservoir must be provided by the customer – see dimensions

** cannot be selected if stacking valves are to be added

*** the usable volume given is the maximum value (achieved with a clean suction filter, low to medium flow rate and viscous fluid!)

Subject to modifications.

Flow rate and pressure

Flow rate				Motor output at 3 ~ 50 Hz 230 / 400 V Motor also suitable for 3 ~ 60 Hz 257 / 480 V } Motor code 03							Motor code 63 1 ~ 50 Hz / 230 V
50 Hz [l/min]	60 Hz [l/min]	No. poles on motor	Displ. pump [ccm/rev]	0.37 kW [bar]	0.55 kW [bar]	0.75 kW [bar]	1.1 kW [bar]	1.5 kW [bar]	2.2 kW [bar]	3.0 kW [bar]	1.5 kW [bar]
1.3	1.6	4	1.0	215	250						250
2.4	2.9	4	2.0	110	170	235	250				250
3.7	4.4	4	2.65	75	115	155	230	250			230
5.0	6.0	4	3.75	50	85	115	170	230	250		180
6.3*	7.6*	4	4.75*	40	70	90	140	185	250		140
7.4	8.9	2	2.65						230	250	
8.6*	10.3*	4	6.3*	30	50	65	100	130	200		100
10.0	12.0	2	3.75						165	230	
12.6*	15.1*	2	4.75*						135	185	
13.3*	16.0*	4	10.0*		30	40	60	85	120		65
17.3*	20.7*	2	6.3*						95	130	
20.0*		2	8.0*						80	110	

4-pole motor types are low-noise

* not possible with oil reservoir B04

Circuit diagram 1

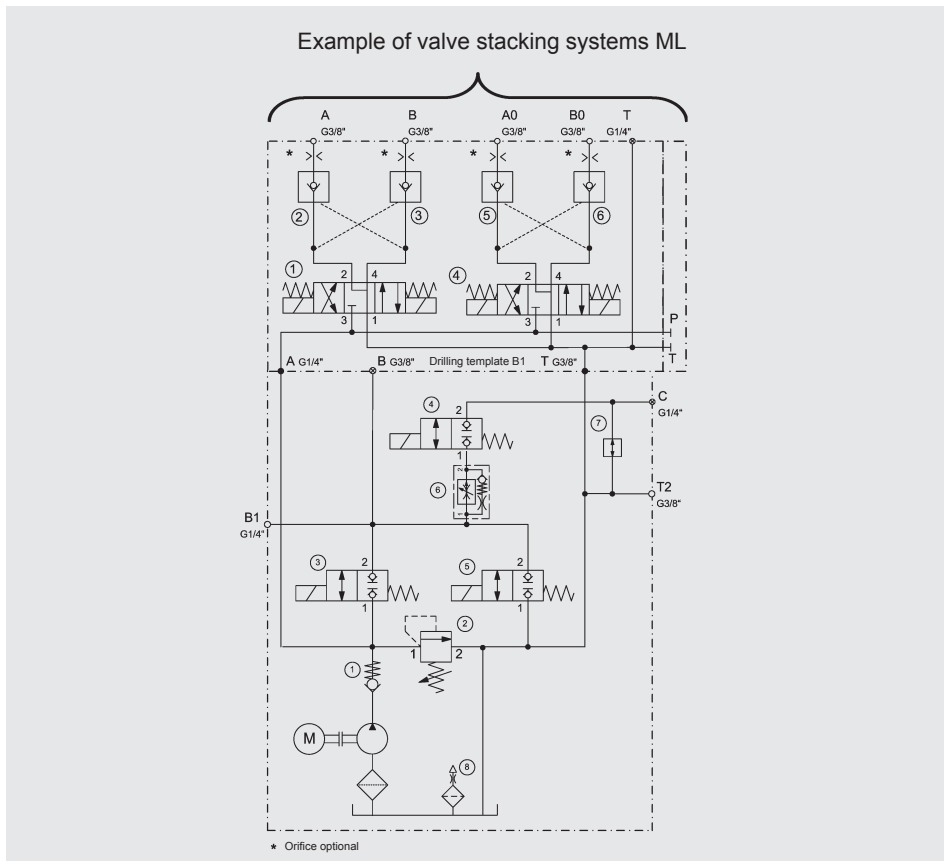

3D model of flange unit

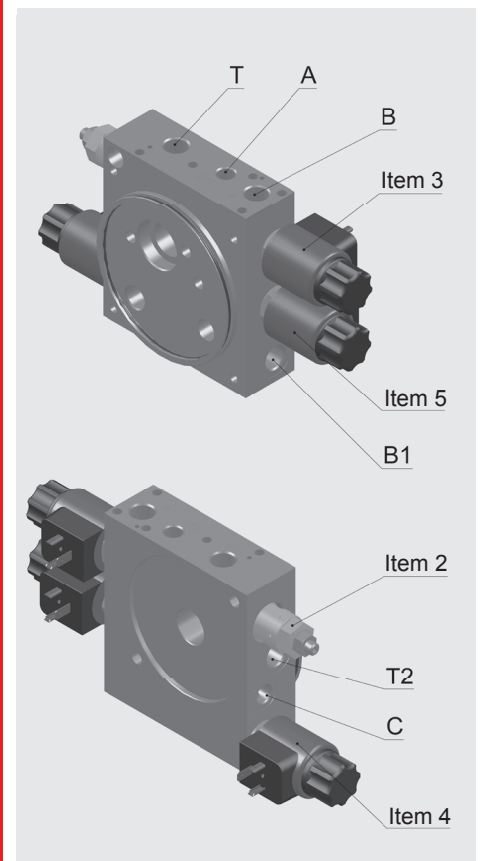

Dimensions

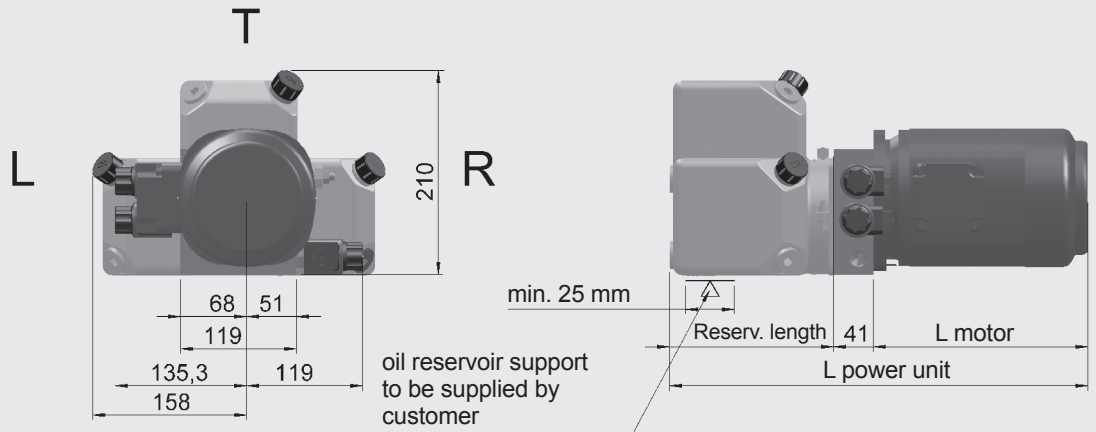

Mounting options on flange underside

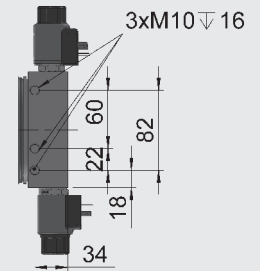

P [kW]	No. of poles	L motor [mm]	\varnothing motor [mm]
0.37	4	220 \pm 5	141 \pm 5
0.55	4	220 \pm 5	141 \pm 5
0.75	4	220 \pm 5	141 \pm 5
1.1	4	255 \pm 5	159 \pm 5
1.5	4	255 \pm 5	159 \pm 5
2.2	2	255 \pm 5	159 \pm 5
2.2*	4	280 \pm 5	176 \pm 5
3*	2	280 \pm 5	176 \pm 5

*On 2.2 and 3 kW motors the flange must have at least 15 mm of support.

Specifications

Flow rate:	up to 20.0 l/min
Continuous pressure:	max. 250 bar
Coil duty rating:	S2 (short-term operation) : 5 min S3 (intermittent duty) : 20 %
Motor:	PN = 0.37 kW ... 3.0 kW (4; 5.5 kW on request)
Motor voltages:	3 Phase 230/400V - 50Hz (other motor voltages on request, min. order 10 pcs.)
Protection class:	DIN EN 60034-5 min IP54
Pump displacement:	1.0 cm ³ /rev. ... 10.0 cm ³ /rev
Reservoir volume:	1.8 - 8.4 l
Usable volume:	1.2 - 7.8 l
Operating fluid:	Hydraulic oil to DIN 51524 Part 2
Temperature range of operating fluid:	-20 °C to max. +80 °C
Ambient temperature range:	-20 °C to max. +40 °C
Viscosity range:	10 - 380 mm ² /s is recommended
Filtration:	Operating fluid to ISO 4406 Class 21/19/16 or cleaner
Cooling:	Convection or air cooling
Weight:	from 12 to 20 kg
Installation:	Vertical, horizontal

Hydraulic circuit 2 (further option MS41)

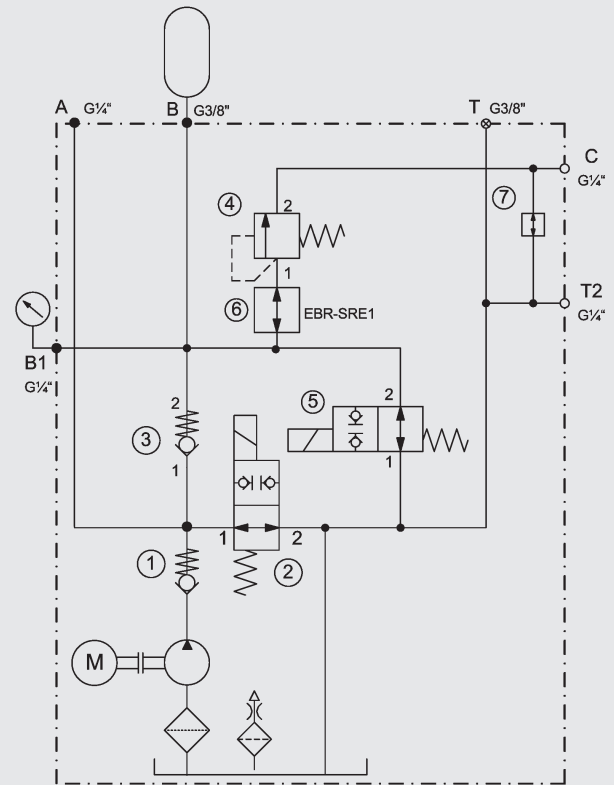

CO1...MS41-VRV-DB210CE-V-0-0-B/SBO3-B1/MA4+24DG

The information in this brochure relates to the operating conditions and applications described.

For applications and operating conditions not described, please contact the relevant technical department.

Subject to technical modifications.

HYDAC Fluidtechnik GmbH

Justus-von-Liebig-Str.

D-66280 Sulzbach/Saar

Tel: 0 68 97 /509-01

Fax.: 0 68 97 /509-577

E-Mail: flutec@hydac.com