



HFM Series

Service and Parts

up to 37 gpm (140 l/min), up to 5800 psi (400 bar)

1. Maintenance

1.1 General

Please follow the maintenance instructions.

1.2 Installation

Before installing the filter into the system, check that the operating pressure of the system does not exceed the permitted operating pressure of the filter. Refer to the type code label on the filter.

Important:

When using filters without bypass valve and at operating pressures above 20 bar, (290 psi), high differential pressure-resistant filter elements of the type BH/HC must be used for safety reasons.

Under extreme conditions (e.g. cold start), bypass valves will allow a partial flow past the element for a short time.

1.3 Commissioning

Check that the correct filter element is installed. Screw in bowl again fully and then unscrew by one quarter-turn (the sealing effect will not be improved by overtightening).

Switch on the hydraulic system and check filter for leakage.

Vent filter at an appropriate point in the system.

1.4 Maintenance Tools

Size	Wrench for filter bowl	Wrench for VD 0 A.1
75-95	Hex 24	Hex 27

1.5 Torque Values Nm[ft-lb]

Type	Max. torque
VD clogging indicator	50Nm[36] (A, LE, LZ) 100Nm[74] (B, C, D)
Bowl	Do not Torque See 1.3 and 2.2

2. Element Replacement

2.1 Element Removal

1. Switch off hydraulic system and release filter pressure.
2. Unscrew filter bowl (drain fluid into a suitable container and clean or dispose of it in accordance with environmental regulations).
3. Remove filter element from element nozzle in filter head (check surface of element for contamination residue and larger particles; these can indicate damage to components).
4. Replace filter element.
5. Clean filter bowl and filter head; particular attention must be given to the threads.
6. Examine filter, especially sealing surfaces, for mechanical damage.
7. Check O-rings – and replace if necessary

2.2 Element Installation

1. Wet the sealing surfaces and thread on the filter head and bowl, as well as the O-ring, with clean operating fluid.
2. When installing a new filter element, check that the designation corresponds to that of the old element.
3. Place filter element carefully on to the element nozzle.
4. Apply silver grade anti-seize (per Mil-PRF-907E) to threads. Screw in filter bowl fully (metal to metal contact) and then unscrew by one quarter-turn.
5. Switch on hydraulic system and vent filter at a suitable point in the system.
6. Check filter for leakage.

NOTE:

Contamination or incomplete pressure release on disassembly can lead to seizing of the bowl thread.

Filter elements which cannot be cleaned must be disposed of in accordance with environmental protection regulations.

FILTER MAINTENANCE

3. Spare Parts

3.1 Spare Parts Drawing HFM 75 – 95

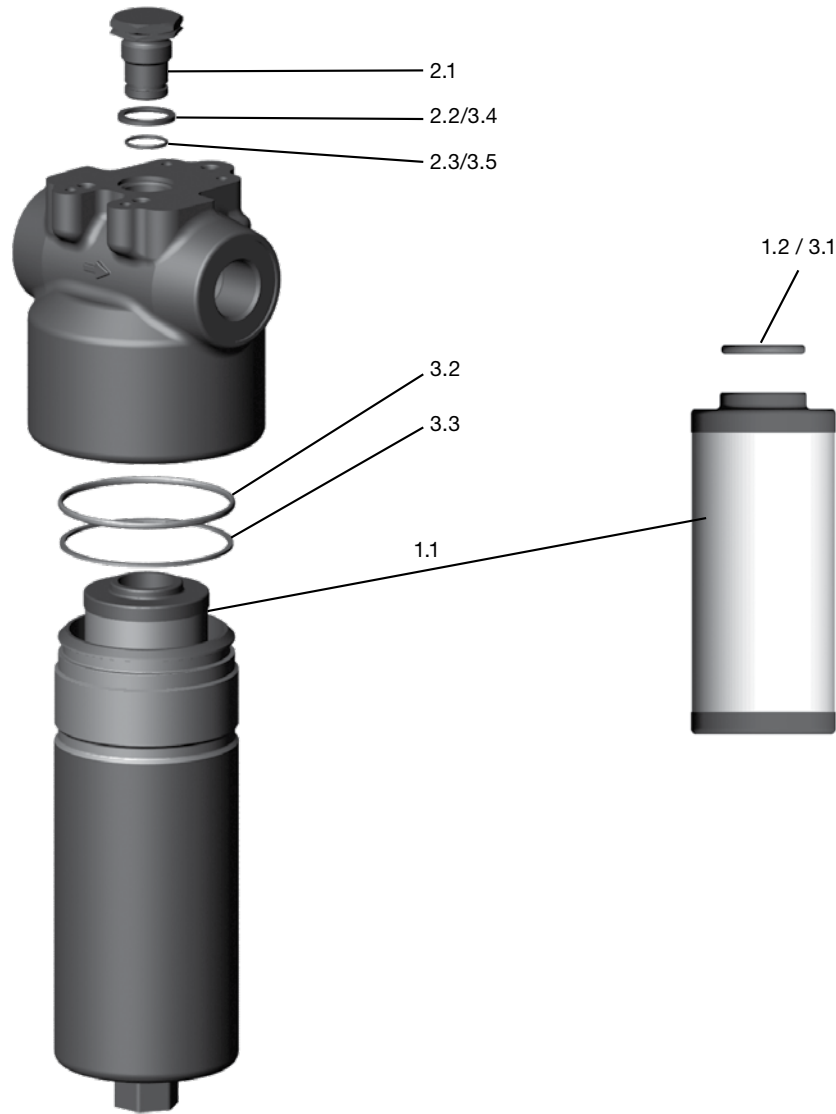

Item	Consists	Designation	75	95
1.		Filter element	See Point 4. Replacement elements	
		Filter element	0075 D...	0095 D...
		O-ring	25 x 3.53	25 x 3.53
2.		Clogging indicator or indicator plug	See Point 5. Replacement clogging indicator	
		Indicator plug VD 0 A.1 VD 0 A.1 /-V	00305932 00305931	
		Profile seal ring	VM...	
		O-ring	18 x 2.5	
3.		Repair kit HFM Repair kit HFM /-V	01280437 01282899	
	3.1	O-ring (element)	25 x 3.53	
	3.2	O-ring (bowl)	67.95 x 2.62 (AS568A-147)	
	3.3	Back-up ring (bowl)	67.2 x 71.6 x 1.4	
	3.4	Profile seal ring (indicator)	VM...	
	3.5	O-ring (indicator)	18 x 2.5	

Other spare parts on request

-O-Ring durometer can range from 70-80Sh. EPR Seal Kits available on request.
-Bowl assembly kits on request - kits include complete bowl with seals.

4. Replacement Element Model Code

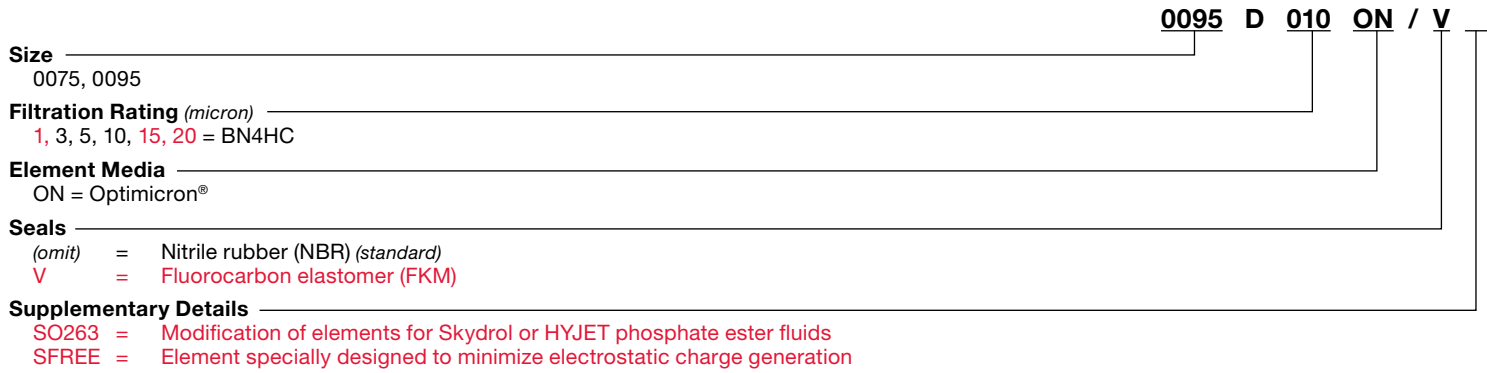

5. Clogging Indicator Model Code

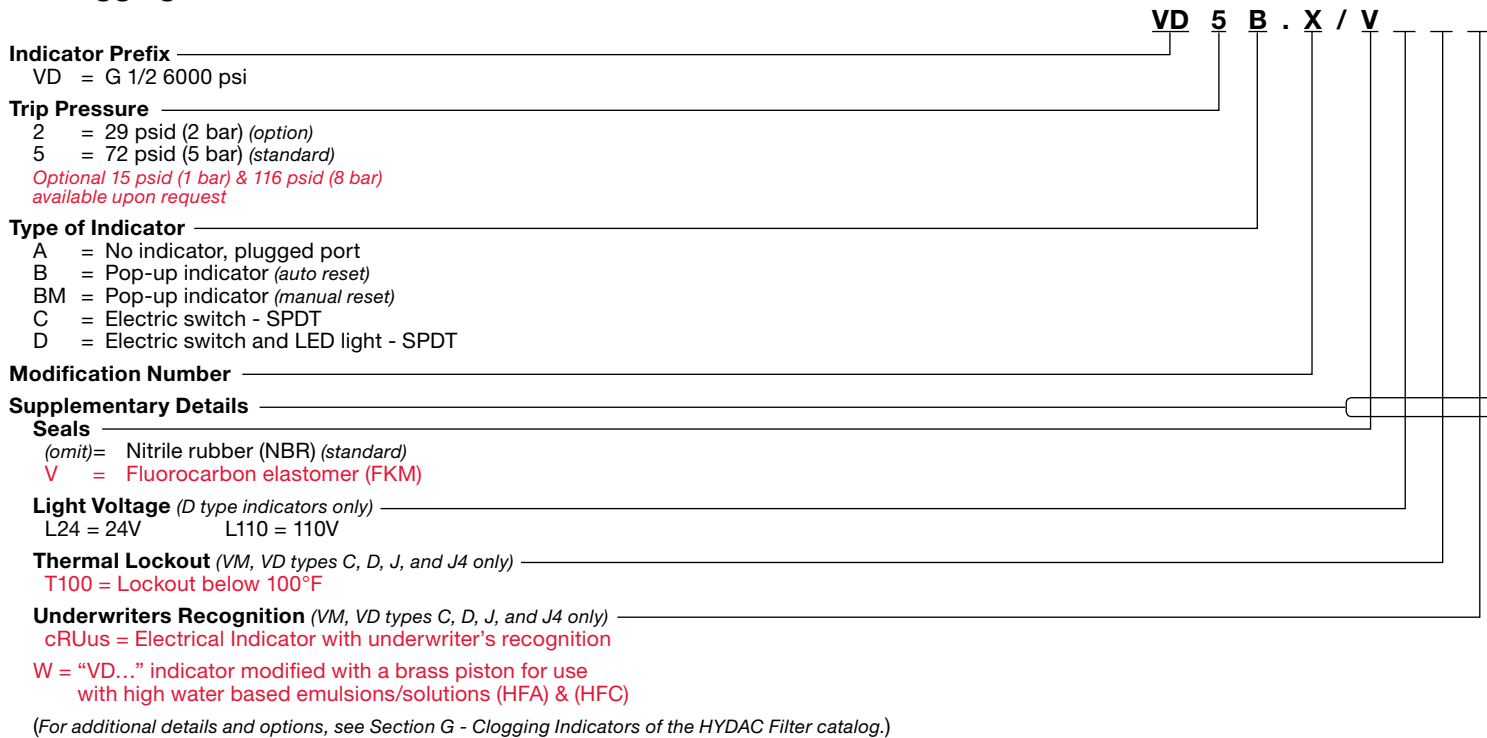

FILTER MAINTENANCE

6. Maintenance Instructions

6.1 User Instructions for Filters



- This pressure equipment must only be put into operation in conjunction with a machine or system.
- The pressure equipment must only be used as stipulated in the operating instructions of the machine or system.
- This pressure equipment must only be operated using hydraulic or lubricating fluid.
- It is the responsibility of the operator to comply with the water regulations of the country concerned.



CAUTION

- The user must take appropriate action (e.g. venting) to prevent the formation of air pockets.
- Repairs, maintenance work and commissioning must only be carried out by trained personnel.
- Allow the pressure equipment to cool before handling.
- The stipulations of the operating instructions of the machine or the system must be followed.
- Statutory accident prevention regulations, safety regulations and safety data sheets for fluids must be observed.
- Filter housing must be grounded.
- When working on, or in the vicinity of, hydraulic systems, open flames, sparks and smoking are forbidden.
- Hydraulic oils and water-polluting fluids must not be allowed to enter the soil or watercourses or sewer systems. Please ensure safe and environmentally friendly disposal of hydraulic oils. The relevant regulations in the country concerned with regard to ground water pollution, used oil and waste must be complied with.
- Whenever work is carried out on the filter, be prepared for hot oil to escape which can cause injury or scalding as a result of its high pressure or temperature.

DANGER!

- Caution: pressure equipment! Before any work is carried out on the pressure equipment, ensure the pressure chamber concerned (filter housing) is depressurized.
- On no account must any modifications (welding, drilling, opening by force...) be carried out on the pressure equipment.
- When using electrical clogging indicators, the electrical power supply to the system must be switched off before removing the clogging indicator connector.

6.2 Maintenance, General

This section describes maintenance work which must be carried out periodically. The operational safety and life expectancy of the filter, and whether it is ready for use, depend to a large extent on regular and careful maintenance.

6.3 Maintenance Measures

- Spare parts must fulfil the technical requirements specified by the manufacturer.
This is always ensured when using original HYDAC spare parts.
- Keep tools, working area and equipment clean.
- After disassembling the filter, clean all parts, check for damage or wear and replace parts if necessary.
- When changing a filter element, a high level of cleanliness must be observed.

6.4 Interval Between Element Changes

In principle we recommend that the filter element is changed every 6 months or upon indication, whichever occurs first.

We recommend installing the filter with a clogging indicator (visual and/or electrical or electronic) to monitor the filter element.

If the clogging indicator responds, it is necessary to change or clean the filter element without delay (only W and V elements can be cleaned).

When no clogging indicator has been installed, we recommend changing the elements at specific intervals. (*The frequency of changing the filter elements depends on the filter design and the conditions under which the filter is operated*). When filter elements are subject to high dynamic loading it may prove necessary to change them more frequently. The same applies when the hydraulic system is commissioned, repaired or when the oil is changed

The standard clogging indicators only respond when fluid is flowing through the filter. With electrical indicators the signal can also be converted into a continuous display on the control panel. In this case the continuous display must be switched off during a cold start or after changing the element.

If the clogging indicator responds during a cold start only, it is possible that the element does not yet need to be changed.

Customer Information in respect of Machinery Directive 2006/42/EC

Hydraulic filters are defined as fluid power parts / components and are therefore excluded from the scope of the Machinery Directive, sections 1.4.1 - 1.4.3. They do not bear the CE mark.

Before using these components, ensure compliance with the specifications provided by HYDAC Technology Corporation. The specifications also contain information on the relevant essential health and safety requirements (based on Machinery Directive 2006/42/EC).

We hereby declare that the filters are intended to be incorporated into machinery within the terms of the Directive 2006/42/EC. It is prohibited to put the filters into service until the machinery as a whole is in conformity with the provisions of the Machinery Directive.

Service address

HYDAC Technology Corporation Filter Division

2260 City Line Road
Bethlehem, PA 18017
+1.610.266.0100

NOTE

The information in this brochure relates to the operating conditions and applications described.

For applications or operating conditions not described, please contact the relevant technical department.

Subject to technical modifications.

Global Headquarters
HYDAC INTERNATIONAL
GMBH

Industriegebiet
D – 66280 Sulzbach/Saar
Germany

Tel.: +49 6897 509-01

Fax: +49 6897 509-577

Internet: www.hydac.com
Email: info@hydac.com

North America Locations

USA

www.HYDAC-NA.com

North America Headquarters
HYDAC TECHNOLOGY CORPORATION
Filter Division

2260 City Line Road
Bethlehem, PA 18017
+1.610.266.0100

HYDAC TECHNOLOGY CORPORATION
Electronic Division
Process Filter Division

HYDAC CORPORATION
Accumulator Division
90 Southland Drive
Bethlehem, PA 18017
+1.610.266.0100

HYDAC TECHNOLOGY CORPORATION
Accessory Division

2204 Avenue C
Bethlehem, PA 18017
+1.610.266.0100

HYDAC TECHNOLOGY CORPORATION
Filter System Division
Process Filter Division
Fuel Filtration Division

580 West Park Road
Leetsdale, PA 15056
+1.724.318.1100

HYDAC TECHNOLOGY CORPORATION
Hydraulic Division –
Compact Hydraulics

450 / 445 Windy Point Drive
Glendale Heights, IL 60139
+1.630.545.0800

HYDAC TECHNOLOGY CORPORATION
Hydraulic Division – Tech Center

430 Windy Point Drive
Glendale Heights, IL 60139
+1.630.545.0800

HYDAC TECHNOLOGY CORPORATION
Cooling System Division

1051 Airlie Parkway
Denver, NC 28037
+1.610.266.0100

HYDAC TECHNOLOGY CORPORATION
Mobile Hydraulic Division

1660 Enterprise Parkway • Suite E
Wooster, OH 44691
+1.610.266.0100

HYDAC CYLINDERS LLC

540 Carson Road North
Birmingham, AL 35217
+1.205.520.1220

HYDAC TECHNOLOGY CORPORATION
HYDAC CORPORATION
Sales Office & Operations

510 Stonegate Drive
Katy, TX 77494
+1.281.579.8100

HYDAC TECHNOLOGY CORPORATION
HYDAC CORPORATION
NW Sales Office & Operations

1201 NE 144th St. Bldg. B • Suite 111
Vancouver, WA 98685
+1.610.266.0100

HYDAC TECHNOLOGY CORPORATION
HYDAC CORPORATION
NE Sales Office

1660 Enterprise Parkway • Suite E
Wooster, OH 44691
+1.610.266.0100

HYDAC TECHNOLOGY CORPORATION
HYDAC CORPORATION
SE Sales Office

1051 Airlie Parkway
Denver, NC 28037
+1.610.266.0100

HYDAC TECHNOLOGY CORPORATION
HYDAC CORPORATION
NC Sales Office

9415 West Forest Home Ave. • Suite 200
Hales Corners, WI 53130
+1.610.266.0100

Canada

www.HYDAC-NA.com

HYDAC CORPORATION
14 Federal Road
Welland, Ontario, Canada L3B 3P2
+1.905.714.9322

HYDAC CORPORATION
Sales Office
5160 75 Street NW
Edmonton, Alberta, Canada T6E 6W2
+1.780.484.4228

HYDAC CORPORATION
Sales Office
Montreal, Québec, Canada J2M 1K9
+1.877.539.3388

Mexico

www.HYDACmex.com

HYDAC INTERNATIONAL SA de CV
Calle Alfredo A Nobel No 35
Col Puente de Vigas
Tlalnepantla, Edo Mexico
CP 54090
Mexico
+011.52.55.4777.1262