



# Accessories

Ball Valves Sizes 06-50

KHB, KHM, and KHB3K

Maintenance Instructions



## Warning!

The piping system must be depressurized and the valve removed from service for maintenance. Failure to do so may result in serious personal injury.

## Tools Required

1. Wrenches
2. Vise
3. Seal Lubricant

## Procedure

### Disassemble the Valve

1. Make sure that the valve is in the open position.
2. Remove the two connection adapters (2).
3. Remove the o-rings (11) and the back up rings (15) *(for sizes 32 through 50 only)*.
4. Remove the ball seal (5).
5. Remove the control handle (12).
6. Remove the spring retainer (7) and limit washer (8) from the control spindle (4).
7. Turn the valve to the closed position and remove the ball (3).
8. Remove the spindle (4) by pushing it into the valve body (1).
9. Remove the o-ring (10), the backup ring (9), and thrust washer (13) from the spindle (4).

### Connection Adapter Torque

Valve Size	Installation Torque (ft-lbs)
06	50
10	110
16	135
20	185
25	235
32	295
40	370
50	445

## Reassemble the Valve

1. Clean all parts of the valve.
2. Inspect the valve parts for damage. Replace any worn or damaged parts.
3. Install the new o-ring (10), the backup ring (9), and thrust washer (13) on the spindle (4).
4. Install the spindle (4) in the valve body (1) from inside the valve body.
5. Install o-rings (11), and for sizes 32 through 50, back up rings (15) on the connection adapters (2).
6. Install one connection adapter (2) and one ball seal (5) into the valve body.
7. Rotate the spindle (4) to the closed position as indicated by the slot on the end of the spindle.
8. Align the groove in the ball with the tongue of the spindle (4) and insert the ball (3) so that it fully engages the spindle tongue and ball seal.
9. Install the second ball seal and connection adapter. Torque both connection adapters to the torque values listed in table.
10. Install the limit washer (8), spring retainer (7), and control handle (12).
11. Turn the control handle to check operation of the valve. It should turn smoothly.

**Install the valve in the system and check for leaks.**

## Parts List

Item	Qty	Description	Item	Qty	Description
1	1	Valve Body	9*	1	Spindle Backup Ring
2	2	Connection Adapter	10*	1	Spindle O-Ring
3	1	Ball	11*	2	Connection Adapter O-Ring
4	1	Spindle	12	1	Control Handle
5*	2	Ball Seal	13*	1	Spindle Thrust Washer
6	1	Stop Pin	14	1	Control Handle Fasteners
7	1	Spring Retainer	15*	2	Connection Adapter Backup Ring
8	1	Limit Washer			

\*Item included in seal kit

**KHB / KHM sizes 06-25** (size 06 w/ 6mm spindle)

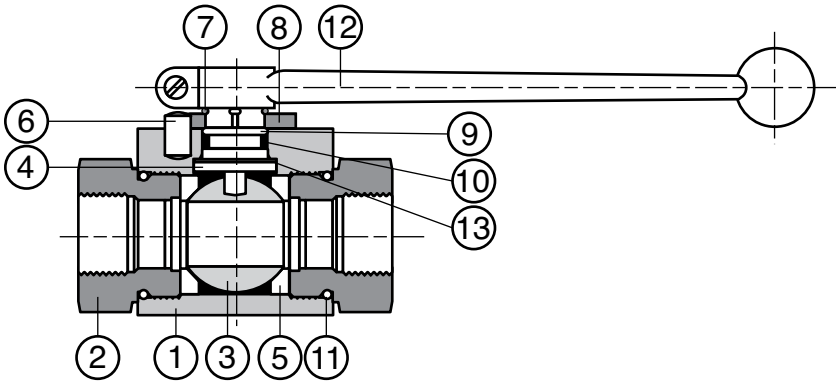

**KHM sizes 32-50**

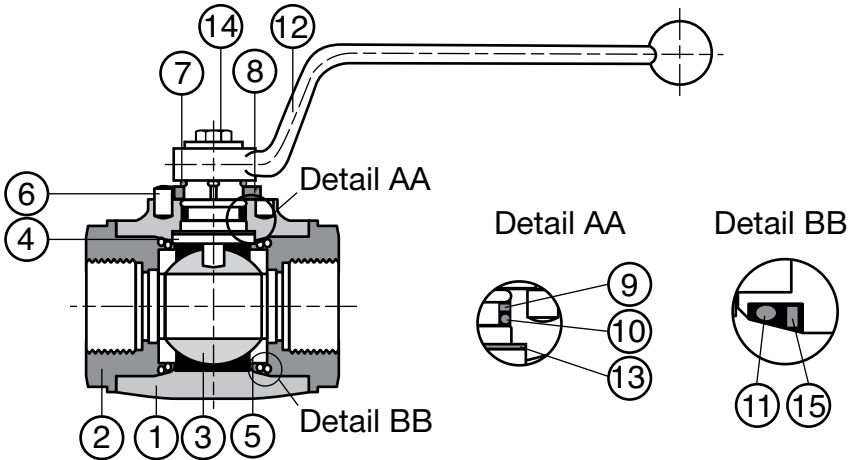

**KHB3K sizes 10-25**

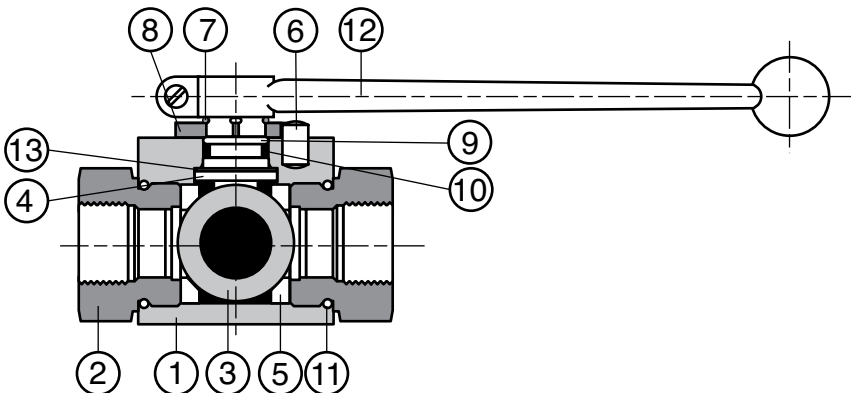



## Accessories

- High Pressure Ball Valves
- Flow Control Valves
- Low Pressure Stainless Steel Ball Valves
- Hose Break, Shuttle, and Air Vent Valves
- Cartridge Valves
- DIN 3015 Clamps
- Cushion Clamps
- Beugu Clamps
- Oval Clamps
- U-bolt Clamps
- Accumulator Clamps
- Series Strips
- Band Straps
- Breathers & Filler Breathers
- Fluid Level Indicators
- Suction Strainers
- Gauge Isolators
- Gauges
- Split Flanges
- TestPoints

**Visit:**

[www.HYDAC-NA.com](http://www.HYDAC-NA.com)

**to download the  
complete HYDAC  
Accessories Catalog!**

