

SK 210 / 250 / 350 / 600 Piston Accumulators

Maintenance and Parts

Index

1. Description
2. Delivery Inspection
3. Installation and Mounting
4. Connection
5. Commissioning and Precautions
6. Inspection and Maintenance
7. Storage and Preservation
8. Disassembly, Inspection and Assembly
9. Special Tools and Spare Parts

1. Description

These Operating and Maintenance Instructions apply to HYDAC piston accumulators of the series SK210, SK350 and SK 600 having the following specifications:

perm. operating pressure: 210 / 350 bar

perm. operating temperature: -10 / 80°C with NBR seal

max. pre-charge pressure p_0 : $p_{0,max} \leq p_1 - 5$ bar

perm. pressure ratio p_0 : $p_2 \leq 1 : \infty$

Design, Approval: PED/AD-Regulations, ASME

For volumes, dimensions and weights (*when empty*), see drawing or brochure.

2. Delivery Inspection

Prior to delivery, HYDAC accumulators undergo a careful inspection. Upon receipt of the accumulator, check that:

- no damage has been sustained during transport. In particular, check the gas valve and the hydraulic connection for damage,
- the details shown on the model code correspond to the order details,
- the test certificates (if required) are present and correspond to the factory number of the accumulator,
- the protective cap of the gas valve is tightly closed,
- the hydraulic connection has been closed off with a protective plug.



CAUTION!

After discharging and/or completely draining the accumulator (e.g. to depressurize the hydraulic system before work is carried out), the accumulator can build-up an amount of pressure again when the lines are later shut off on the fluid side. This problem must be taken into account generally and in particular before carrying out work on hydraulic systems which include connected hydraulic accumulators. All the fluid-side lines connected to the accumulator must therefore be depressurized and after that the lines remain open. Only then may the appropriate work (e.g. disassembly of the accumulator) be carried out.



CAUTION!

PRESSURIZED VESSEL USE DRY NITROGEN GAS ONLY

Please refer to HYDAC Operating and Installation Instructions

3. Installation and Mounting

3.1. Mounting Position

The piston accumulators can be mounted in any position. However, the vertical mounting position with the gas valve at the top is generally preferred.

Sufficient clearance must be left to mount and disconnect the piston accumulator. In particular, an area of at least 150 x 150 x 150 mm must be left above the gas valve for fitting and operating the charging and gauging unit.

3.2. Mounting

In accordance with the recommendations of the HYDAC brochure "Mounting Components", HYDAC piston accumulators must be mounted vibration free using clamps and base brackets.



Note: Mounting elements must never be welded to the piston accumulator.

4. Connection

The connection of the accumulator to the system must be stress free and torque free.

It must be possible to isolate the accumulator from the pressurized hydraulic system.

5. Commissioning and Safety Precautions

5.1 Commissioning

Prior to connecting the accumulator to the pressurized system, the precharge pressure should be rechecked. If the accumulator was precharged at HYDAC the pressure level can be found on the label.

The level of the precharge pressure generally depends on the following criteria:

- type of system,
- expected changes in operating temperature,
- intended function of the accumulator.

The following precharge pressures are recommended:

for energy storage:

$$p_{0,tmax} \leq P1 - 5 \text{ bar}$$

$$p_{0,tmin} \geq 2 \text{ bar}$$

for volume compensation:

p_0 = static pressure of the system

Further information on the gas precharge pressures can be found in the HYDAC accumulator brochure "Piston Accumulators". Charging and gauging of the precharge pressure is described in Point 6 "Inspection and Maintenance".

5.2. Venting

Prior to commissioning, the accumulator must be vented on the oil side. Then apply the maximum operating pressure to the complete hydraulic system and check for leakages.

5.3. Safety Precautions



IMPORTANT!

Only use nitrogen to charge the accumulator, never oxygen or compressed air (*risk of explosion*).

If the pressure of the nitrogen bottle is higher than the permissible operating pressure of the accumulator, a pressure regulating valve must be fitted.

6. Inspection and Maintenance

On the whole, nitrogen losses on piston accumulators are very low. However, it is advisable to check the precharge pressure p_0 at least once during the first week following commissioning so that larger nitrogen losses can be detected immediately. During the course of the first two months check the precharge pressure every two weeks, and thereafter every four weeks. If after this period no pressure change is detected, an annual check of the nitrogen pressure is sufficient.

6.1. Checking the Nitrogen Pressure without a Charging and Gauging Unit

In this case, as shown in the following drawing, a pressure gauge is connected to a line which is directly connected to the accumulator.

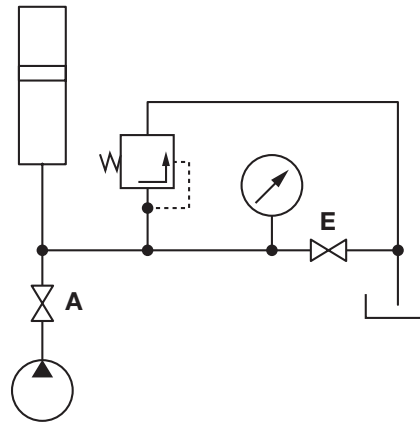

Isolate the fully charged piston accumulator from the hydraulic system by closing the shut off valve A. Slowly discharge the accumulator on the fluid side via drain valve E. The pressure gauge must be constantly monitored during this process. A slow, steady pressure drop is displayed. The pressure only drops abruptly when the accumulator has been completely discharged. The pressure displayed before the drop corresponds to the precharge pressure of the piston accumulator. If this pressure lies below the permissible value, the charging procedure must be carried out, as described in the following section.

6.2. Charging Procedure with the Charging and Gauging Unit

Using the charging and gauging units, hydraulic accumulators can be charged with nitrogen or tested to the precharge pressure P_0 .

First, isolate the piston accumulator from the hydraulic system by closing the shut off valve A and discharge it on the fluid side. Then remove the valve seal cap of the piston accumulator.

When using accumulators with gas valves version 1 the gas valve insert must first be unscrewed slightly (*approx. 1/2 turn*) using a 6mm allen wrench.

The T-handle of the FPU-1 must not be used for this. Now the charging and gauging unit can be connected.

When using accumulators with gas valve version 4, the valve seal cap must first be unscrewed. Only then can the charging and gauging unit and the nitrogen bottle be connected in accordance with the operating instructions (*with adapter A3*). Ensure that the pressure release valve of the charging and gauging unit is closed. Turn the spindle in a counter-clockwise direction to unscrew the internal hex screw of the gas valve. Then slowly open the valve of the nitrogen bottle so that the nitrogen is released into the accumulator. Wait until approximately 1 bar precharge pressure has been reached and the piston is at the fluid side before opening the shut off valve of the nitrogen bottle further to enable faster charging.

Gas Valve Version 4 Gas Valve Version 1

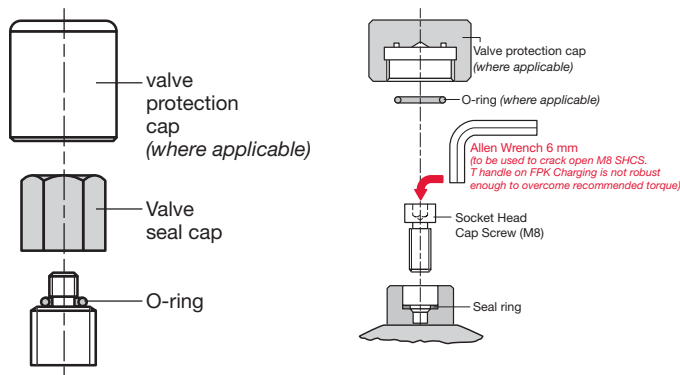

Interrupt the charging procedure from time to time and check the precharge pressure reached. When the required precharge pressure has been reached, close the shut-off valve of the nitrogen bottle. Wait for approx. five minutes until temperature equalization is reached (*a longer period must be allowed for larger systems quantities*), then recheck the precharge pressure and adjust if necessary. If the pressure is too high, it can be lowered via the pressure release valve of the charging and gauging unit.

Turn the spindle clockwise to securely tighten the internal hex screw. Then discharge the charging and gauging unit via the pressure release valve and remove it by loosening the cap nuts. On piston accumulators with gas valve version 1, the internal hex screw must be tightened to a torque rating of 20 Nm and with version 4 the valve seal cap must be tightened to a torque rating of 30 Nm. Finally check for leaks on the accumulator gas valve using a leak detector spray. Screw on valve protection cap.

Further details can be found in the operating instructions for part number 02068202.

6.3. Pressure Testing

For piston accumulators with a permissible operating pressure p greater than 1 bar and a pressure capacity $p \cdot V > 1000$, for non-corrosive fluids, a pressure test must be carried out by an approval authority every 10 years, otherwise every 5 years.

An internal inspection must be carried out every five years and an external inspection every two years.

7. Storage and Preservation

If the period of storage until commissioning is no longer than three months, it is sufficient for the precharged accumulator to be stored in a cool, dry place, protected from direct sunlight, providing that the inside of the accumulator has first been coated with the intended hydraulic fluid. The accumulator can be stored in any position. To prevent contamination from entering the accumulator, ensure that the hydraulic connection is plugged.

If the accumulator is to be stored for longer than three months, check the required precharge pressure of the accumulator before commissioning.

If the accumulator has not been precharged, it must be plugged on the gas side and conserved with the intended operating fluid or another suitable conservation fluid.

8. Disassembly, Inspection and Assembly

8.1 Removal From System

- Carefully clean the area around the end caps on the gas and fluid side.
- On backup type piston accumulators the nitrogen feed line must be isolated by means of the shut off valve.
- Completely release the pressure on the fluid side of the accumulator. This causes the piston to move down to the end cap on the fluid side with the aid of the gas precharge pressure.
- Connect the charging and gauging unit according to the operating instructions and section 6.2. and release the pressure slowly by opening the pressure release valve.
- Remove all non pressurized lines on the gas and fluid side and remove the complete piston accumulator from the system.

8.1.1 Disassembly

Further disassembly should be carried out in a suitable, clean area.

- Clamp piston accumulator to a work bench and remove the gas valve and all adapters and accessories.
- Unscrew end caps on the gas and fluid side. This can be achieved by using 2 bolts or threaded rods positioned opposite each other. On large end caps an extension rod can be used.
- If the end cap is in two parts, then the connection screws between the threaded ring and end cap must be loosened first. Unscrew the threaded ring by approximately 3 turns and screw in the connection screws again. This pulls the end cap out. Carry out this process several times until the end cap is completely free.
- Push the piston out of the accumulator in the direction of the fluid side (*use suitable plastic or wooden rod and a rubber mallet*). Both threaded bores in the piston can be used for this purpose.

8.1.2 Testing and Cleaning

a) Cylindrical tube

Carefully clean the inside of the cylindrical tube (piston body) with a non aggressive, non abrasive cleaning agent and then dry with a lint free cloth. Check the inside of the tube for rough spots and grooves. If these are found, it is possible for HYDAC to remachine the cylindrical tube within certain tolerances.

If any external or internal damage is found, the pressure vessel must be submitted to the manufacturer and, if applicable, the appropriate inspection authority for assessment.

b) End caps

Carefully clean the end caps and replace both O-rings.

c) Piston

Remove all seals and guide rings and clean the piston thoroughly.

8.1.3 Assembly

a) Fitting the piston seals

Piston design type 2:

- Guide the mounting sleeve (*see point 9 – Special tools and spare parts*) over the piston from the fluid side as far as the groove provided for the center seal (*see part of center seal*).
- Draw the elastomer ring over the sleeve into the groove provided. Then heat the center seal ring to 150°C to facilitate fitting and push it over the mounting sleeve into the designated position (*shoulder towards the oil side*). This process must be completed in 10 to 15 seconds.
- Push the quadring into the recess of the seal ring (*see figure*).

- Withdraw the mounting sleeve as far as the groove for the seal ring and fit elastomer O-ring. Then heat the seal ring to 150°C to facilitate fitting and press into the designated position over the mounting sleeve (*shoulder towards the oil side*). This process must be completed in 10 to 15 seconds.
- Fit guide rings both on the gas as well as the oil side with the ends displaced by 180°.

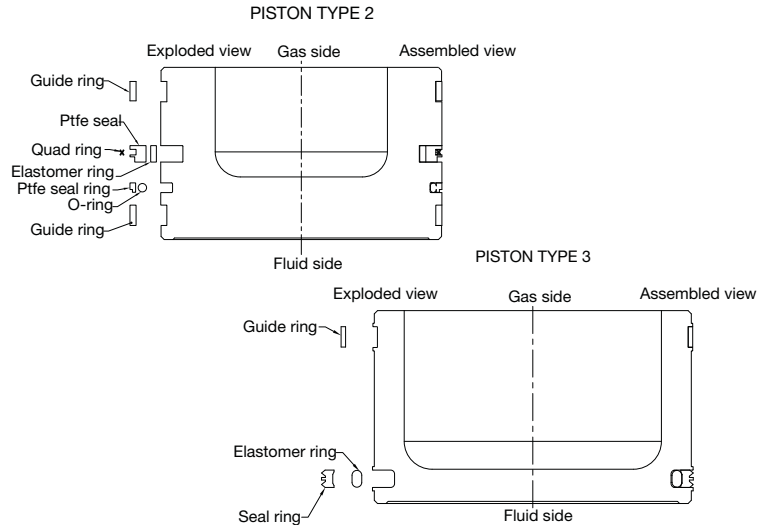

Piston design type 3:

- Fit elastomer O-ring into the designated groove and then draw the seal ring over it.
- Fit guide rings both on the gas as well as the oil side with the ends displaced by 180°.

b) Fitting the piston

- Lubricate the upper area of the cylinder wall and the guide ends of the piston with a suitable lubricating agent (*filtered operating fluid*). Do not use grease or water - water is not a lubricant!
- Place mounting sleeve (*see section 9 – Special tools and spare parts*) onto the cylindrical tube.
- With the hollow side towards the gas connection, insert the piston fully into the tube. A plastic or wooden rod or a rubber mallet can be used for this purpose.
- Grease both O-rings and the threads on the end caps.
- Screw both end caps, or end caps with threaded ring, into the cylindrical tube, if necessary with the aid of the two bolts and a rod, until they are level with the ends of the accumulator.
- If specified, the accumulator must be filled on the gas side with the designated quantity of oil.
- Fit the gas valve and all adapters and other accessories.
- Connect HYDAC charging and gauging unit and charge the accumulator according to the instructions (*see section 6.2*) with the required precharge pressure.
- On piston accumulators with the gas valve version 1, the internal hex. screw must be tightened to a torque rating of 20 Nm and with version 4, the valve seal cap must be tightened to a torque rating of 30 Nm.
- Screw on valve protection cap.

c) Fitting the accumulator into the system

Reconnect the piston accumulator to the system and check for leaks according to section 6 - Inspection and Maintenance.

8.2. Piston Accumulator with Protruding Piston Rod

8.2.1 Disconnection, Disassembly, Testing and Cleaning

Disconnect the piston accumulator as described in section 8.1.

8.2.2 Assembly

a) Fitting the piston seals

Fit the piston seals as described in point 8.1.4 a)

b) Assemble the piston accumulator

- Fit piston rod into the piston base.
- Lubricate the upper part of the cylinder wall and the guide ends of the piston with a suitable lubricant (*filtered operating fluid*). Do not use grease or water - water is not a lubricant!
- Place mounting sleeve (*see section 9 - Special tools and spare parts*) onto the cylindrical tube.
- With the hollow side towards the gas connection, insert the piston fully into the tube. A plastic or wooden rod or a rubber mallet can be used for this purpose.
- Grease both O-rings and the threads on the end caps.
- Screw in both end caps, or end caps with threaded ring, into the cylindrical tube, if necessary with the aid of the two bolts and a rod, until they are level with the ends of the accumulator.
- If specified, the accumulator must be filled on the gas side with the designated quantity of oil.
- Fit the gas valve and all adapters and other accessories.
- Push the guide block, fitted with an O-ring, over the piston rod and screw it firmly to the end cap.
- Fit the rubber packing seal kit in the groove provided.
- Place the sealing flange with the skimmer in position and screw on.
- Connect HYDAC Charging and Testing Unit FPU-1 and charge the accumulator according to the instructions (*see section 6.2*) with the required pre-charge pressure.
- On piston accumulators with the gas valve version 1, the internal hex. screw must be tightened with a torque rating of 20 Nm and with version 4, the valve seal cap must be tightened with a torque rating of 30 Nm.
- Screw on valve protection cap.

c) Fitting the accumulator into the system

Reconnect the piston accumulator to the system and check for leaks according to section 6 - Inspection and Maintenance.

8.3. Piston Accumulator with Electrical Limit Switch

For item numbers, see section 9.2.3.

8.3.1 Disconnection, Disassembly, Testing and Cleaning

Disconnect the piston accumulator as described in section 8.1.

8.3.2 Assembly

a) Fitting the piston seals

Fit the piston seals as described in section 8.1.4 a)

b) Assemble the piston accumulator

- Lubricate the upper part of the cylinder wall and the guide ends of the piston with a suitable lubricant (*filtered operating fluid*). Do not use grease or water - water is not a lubricant!
- Place mounting sleeve (*see section 9 - Special tools and spare parts*) onto the cylindrical tube.
- With the hollow end towards the gas connection, insert the piston fully into the tube. A plastic or wooden rod or a rubber mallet can be used for this purpose.
- Grease both O-rings and the threads on the end caps.
- Fit the limit switch with the O-ring in place.
- Screw in both end caps, or end caps with threaded ring, into the cylindrical tube, if necessary with the aid of the two bolts and a rod, until they are level with the ends of the accumulator.
- If specified, the accumulator must be filled on the gas side with the designated quantity of oil.
- Fit the gas valve and all adapters and other accessories.
- Connect HYDAC Charging and Testing Unit FPU-1 and charge the accumulator according to the instructions (*see section 6.2*) with the required precharge pressure.
- On piston accumulators with the gas valve version 1, the internal hex. screw must be tightened with a torque rating of 20 Nm and with version 4, the valve seal cap must be tightened with a torque rating of 30 Nm.
- Screw on valve protection cap.

c) Fitting the accumulator into the system

Reconnect the piston accumulator to the system and check for leaks according to section 6 - Inspection and Maintenance.

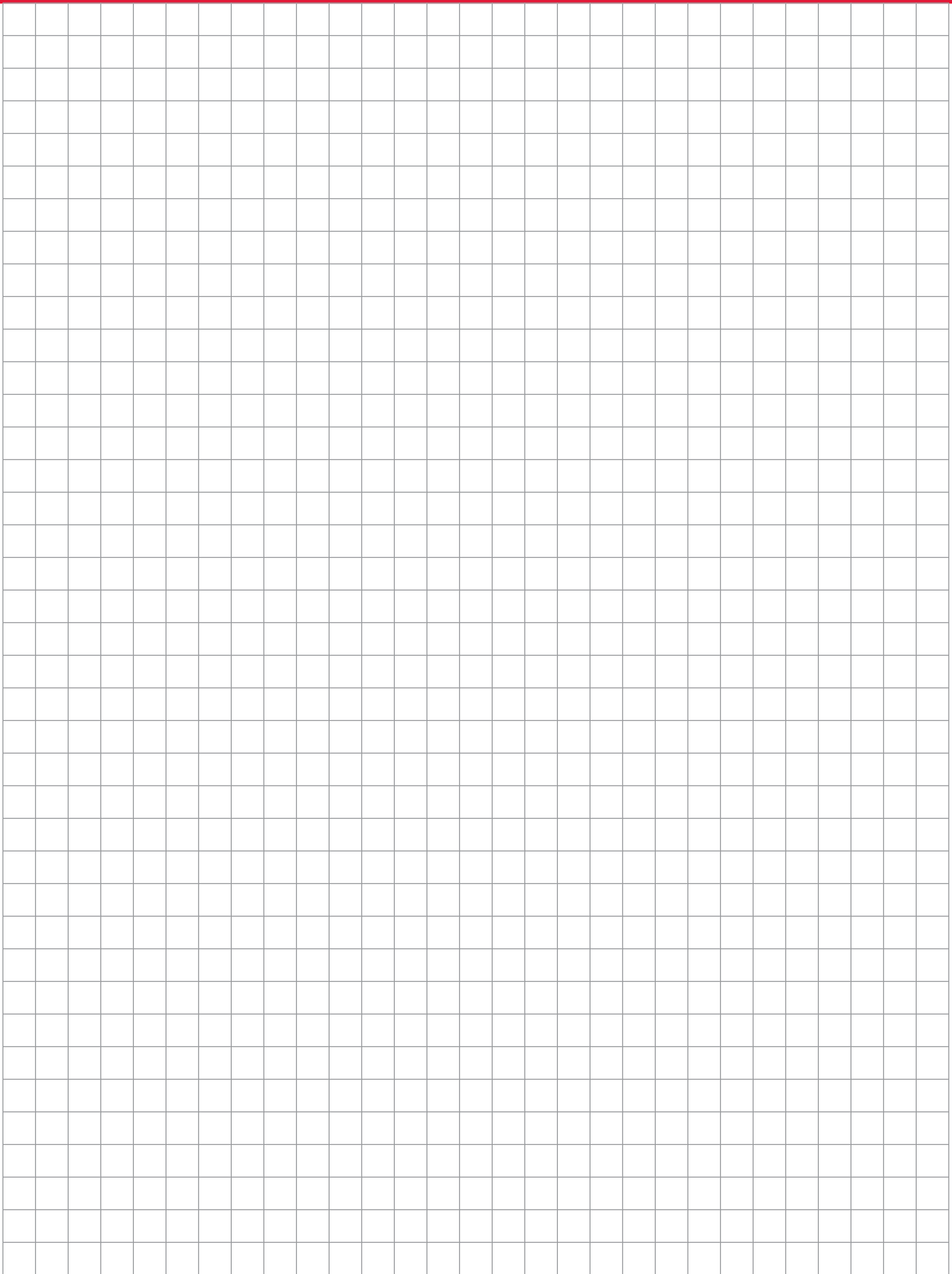



9. Seal Kits & Replacement Pistons

For seal kits other than Buna N, and for sizes not listed please consult factory.

Example: SK 350 - 20 / 2112 S - 210 FCF - VE - 18 E - 1 (see page 38 for details)

Piston Type

Diameter

Piston Seal Kits

Diameter	Type 2 (NBR)	Type 3 (PUR/NBR)
06 (60mm)	—	3016210
08 (80mm)	2123890	3013230
10 (100mm)	3671731	2123414
12 (125mm)	—	2128104
15 (150mm)	3016235	3145418
18 (180mm)	363270	2123415
25 (250mm)	3671733	3016213
31 (310mm)	301600	—
35 (355mm)	363272	—
49 (490mm)	3104100	—

Replacement Pistons - w/ Seals

Diameter	Type 2 (NBR)	Type 3 (PUR/NBR)
06 (60mm)	—	3009372
08 (80mm)	352225	2119931
10 (100mm)	356847	2115547
12 (125mm)	3016232	3016150
15 (150mm)	3016228	3016231
18 (180mm)	2118451	3046277
25 (250mm)	353980	3016171
31 (310mm)	356382	—
35 (355mm)	356382	—
49 (490)	3462428	—

Piston Accumulators: Tools

When repairing a piston accumulator, it is critical to use the appropriate tools to avoid seal damage. There are two tools required:

Seal Assembly Tool:

allows for gradual and even stretching of the seals when installing them onto the piston

Piston Insertion Tool:

a tapered shroud that protects the seals from the threaded portion of the shell, and provides even seal compression and piston alignment when inserting the piston into the shell.

For items not listed please consult factory.

WARNING: Only qualified persons should perform maintenance on any type of accumulator.

For addition information please contact HYDAC.

© Copyright 2015 HYDAC TECHNOLOGY CORPORATION Accumulator Division • Brochure - Service Bladder Accum / PN#2202310 / 02.15 / ACU1502-1667

Tools

Diameter	Seal Assembly	Piston Insertion
08 (80 mm)	359537	359614
10 (100mm)	352198	290056
12 (125mm)	3016278	2128223
15 (150mm)	2124157	2124161
18 (180mm)	350148	290049
25 (250mm)	290035	290046
31 (310mm)	2127304	2127305
35 (355mm)	354147	3389677
49 (490mm)	3114220	3440695

Seals Included with Piston Seal Kit

